

**PANTUM**



**AFTER-SALES  
SERVICE**

# Pantum 1820/2023 Series Technical Training

Customer Service

[WWW.PANTUM.COM](http://WWW.PANTUM.COM)



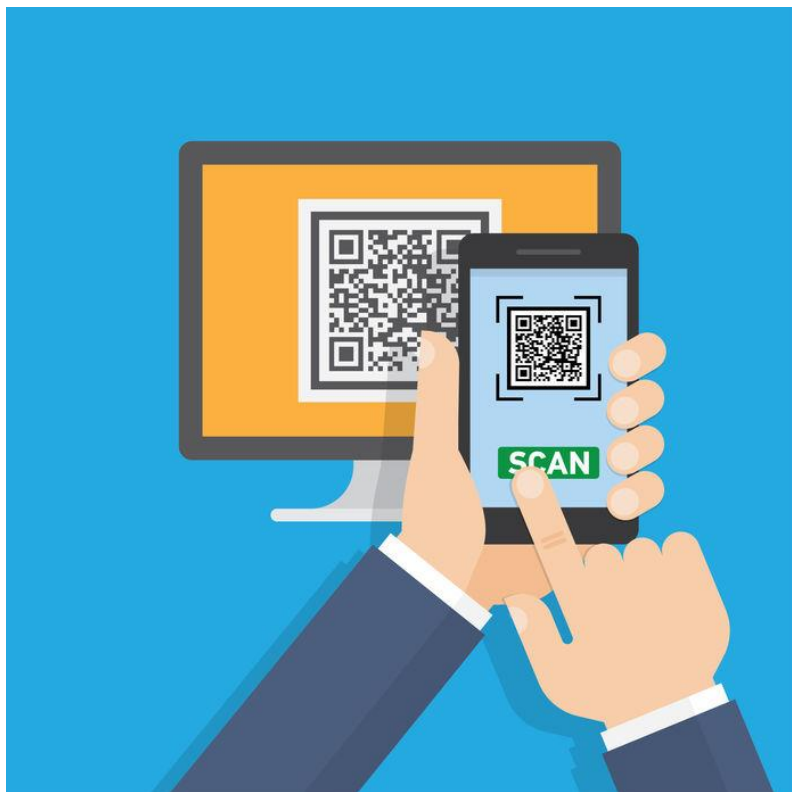

**SIGN HERE  
PLEASE!**





**01** Product  
Information

**02** Principle  
Introduction

**03** Machine Component  
Structure

**04** Common  
Troubleshooting

**05** Maintenance Manual  
Introduction

**06** Printer  
Disassembly



# SECTION 01

## Product Information

**1.Product Series Introduction**

1820 SFP



CP1100 Series

1820 MFP (FB)



CM1100 Series

1820 (ADF)



CM1100A Series

2023SFP



CP2100 Series

2023MFP



CM2100 Series

***New***  
Generation  
Product

**2.Product Series Parameter Introduction**

Product Series Parameter		CP1100 Series	CM1100 Series	CM1100A Series	CP2100A Series	CM2100 Series
Interface type	USB	●	●	●	●	●
	NET	●(N is the suffix of the model name)	●(N is the suffix of the model name)	●(N is the suffix of the model name )	●(N is the suffix of the model name )	●(N is the suffix of the model name )
	Wi-Fi	●(W is the suffix of the model name)	●(W is the suffix of the model name)	●(W is the suffix of the model name)	●(W is the suffix of the model name)	●(W is the suffix of the model name)
Print language	GDI	×	×	×	●	●
	PDL	●	●	●	×	×
Control Panel		CP1100 (USB machine) : LED Other: LCD	LCD	Touch screen	CP2100D (USB machine) LED Other: LCD	CM2100: LCD CM2100A: Touch screen
Print Speed A4		18ppm	18ppm	18ppm	20ppm	20ppm
Double side printing		●	●	●	●	●
Copy Function		×	●	●	×	●
Scan Function		×	●	●	×	●
ADF		×	×	●	×	CM2100: × CM2100A: ●

(●: support, ×: not support)



# SECTION 02

## Principle Introduction

## 1. Print/copy/scan data transfer

### Print

Computer sends out the Print Task

Computer/Printer driver decoding

Printer data board receives electronic data

After the image being formed, it will be printed out directly.

### Copy

The same as Scan  
( The task is initiated by the operator panel )

The same as Scan

The same as Print

The same as Print

### Scan

The original file is placed on the ADF or the platen to initiate scanning through the scan driver

CIS scanning converts light signals into electrical signals

Transfer scan data to computer

## Color principle

3 primary colors of light

Red, Green, Blue

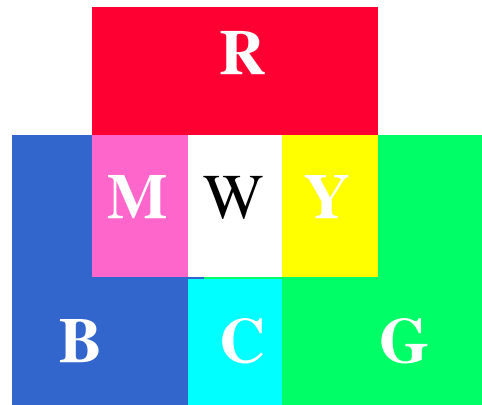

$$R + B + G = W$$

$$R + B = M$$

$$R + G = Y$$

$$B + G = C$$

3 primary colors of printer

Cyan, Magenta, Yellow

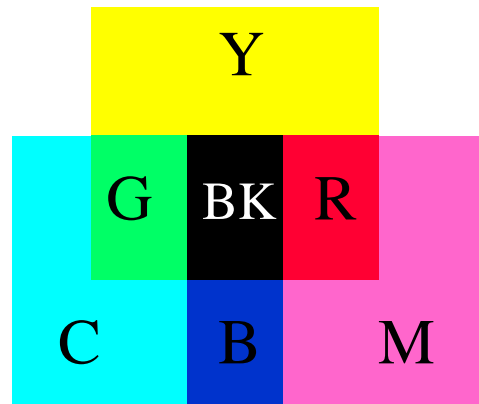

$$Y + M + C = BK$$

$$Y + M = R$$

$$Y + C = G$$

$$M + C = B$$

## Imaging Principles - Monochromatic Imaging

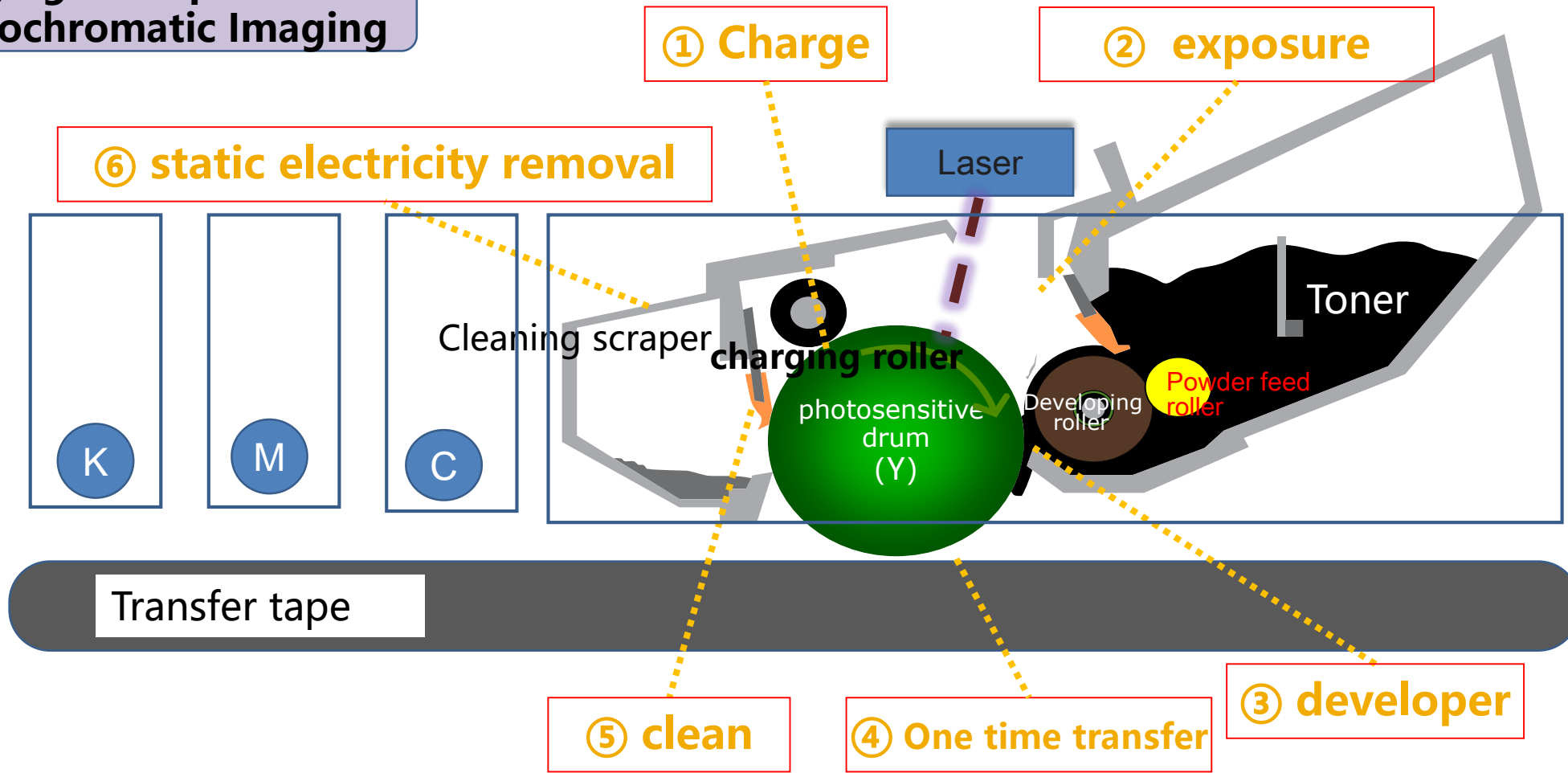

## Imaging Principles - Monochromatic Imaging

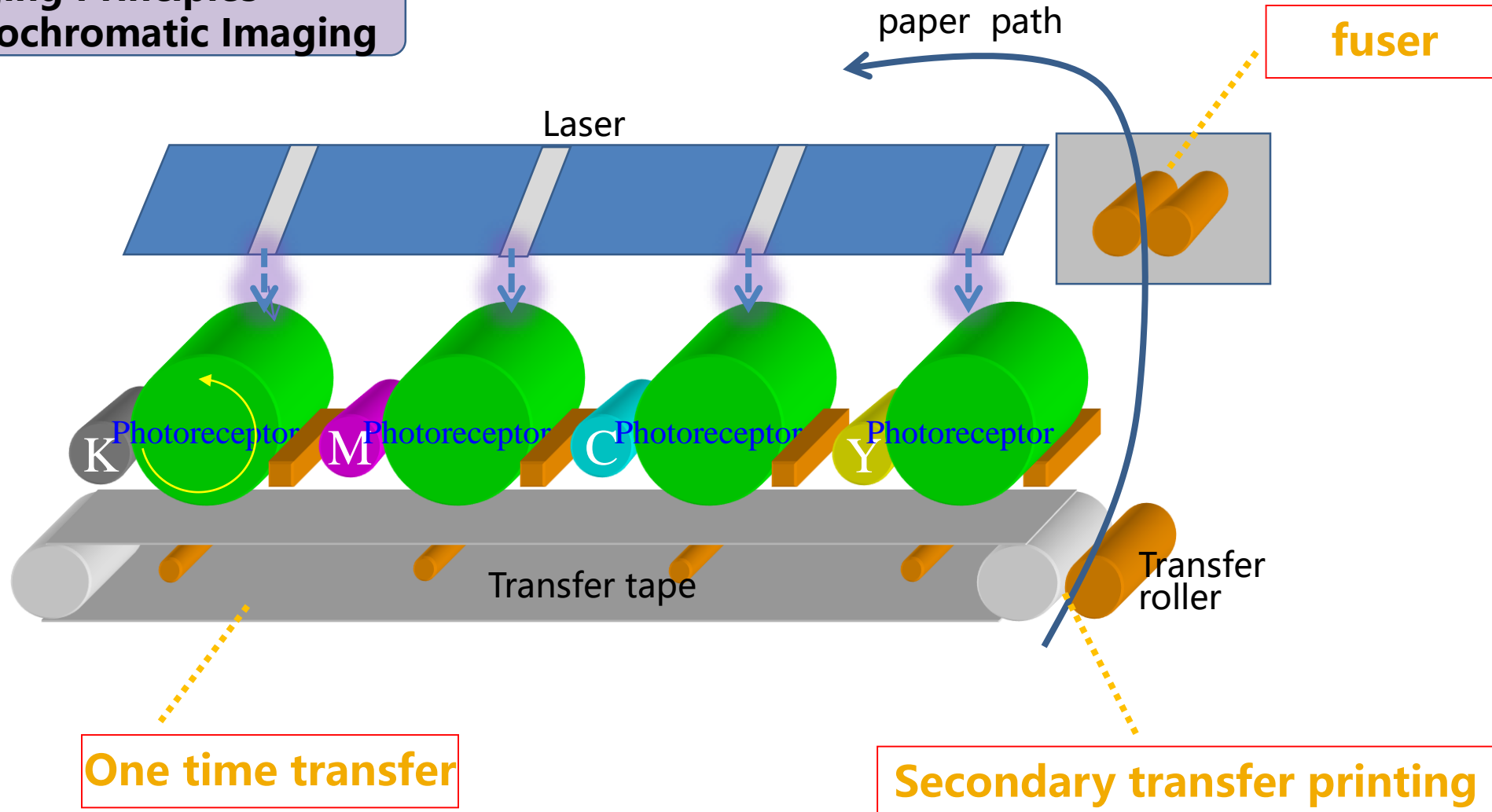

## 4.1 Imaging principle - Charging

The voltage is transferred from the HVPS to the charging roller on the four photo drums. In this printer, the charging roller is a part of the print box. The charging roller applies a uniform negative charge on the entire surface of the photoreceptor drum to prepare for the laser beam irradiation .

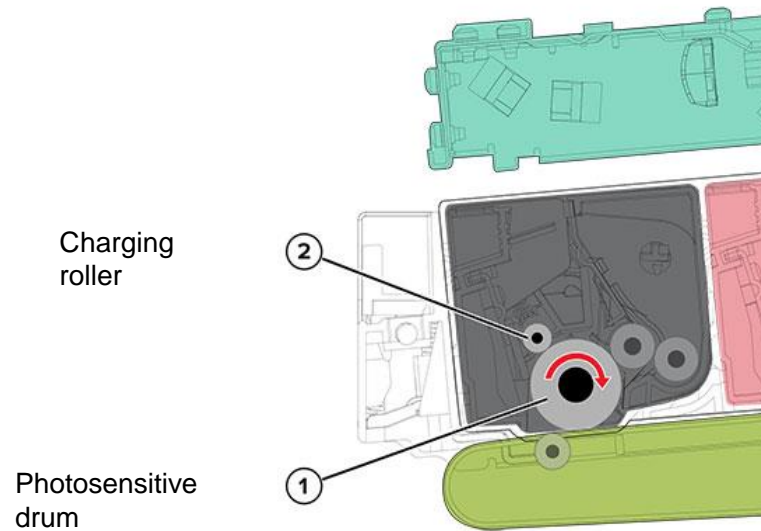

- ◆ If the surface of the charging roller is damaged (for example, there are nicks or pits), it can lead to uneven charge on the photosensitive drum, and periodic poor image may appear on the printed page. If the charging roller is severely damaged, the surface of the photosensitive drum will not be able to charge properly, resulting in excessive toner particles covering the photosensitive drum.

## 4.2 Imaging principle - exposure

The laser will send a focused beam to each drum surface to write an invisible image. The image formed by each color is called latent image or electrostatic image. The laser beam only discharges the surface, making the beam hit the drum. This discharge will generate a potential difference between the exposure area and the rest of the drum surface.

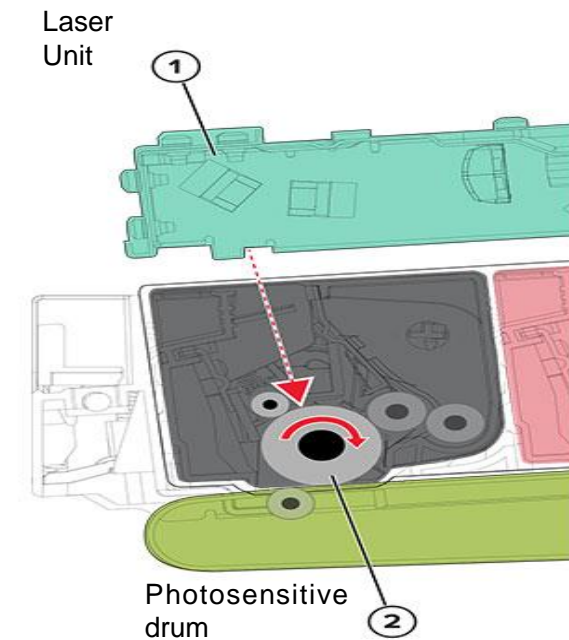

- ◆ If the surface of the charging roller is damaged (for example, there are nicks or pits), it can lead to uneven charge on the photosensitive drum, and periodic poor image may appear on the printed page. If the charging roller is severely damaged, the surface of the photosensitive drum will not be able to charge properly, resulting in excessive toner particles covering the photosensitive drum.

## 4.3 Imaging principle - Develop

The high-voltage substrate transfers the charge to the developing roller, and the developing roller is evenly adhered with carbon powder. Due to the charge difference between the developing roller and the drum, the toner is adsorbed to the laser exposure area on the surface of the drum .

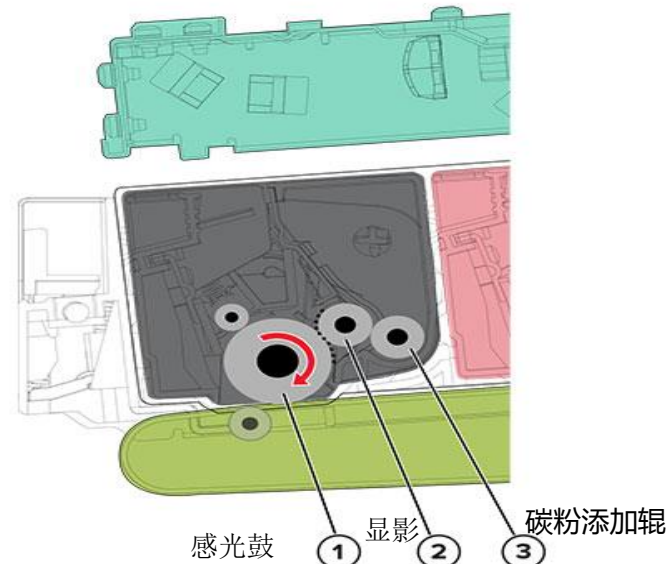

- ◆ Do not touch the surface of the developing roller directly with your hands. Grease on the skin can cause a charge difference on the surface, preventing toner from continuing to adhere correctly, and can lead to repeated blank spots or light color printing on the page. If the developing roller is damaged, it will not be able to properly contact the surface of the photosensitive drum, which may cause periodic dots, vertical white lines, or vertical color lines to appear on the printed page.

## 4.4 Imaging principle - First transfer

The high-voltage substrate transmits the voltage to the first transfer roller inside the transfer belt. Each color of toner transfers the image of the drum surface to the surface of the transfer belt through the charge difference between the drum surface and the first transfer roller.

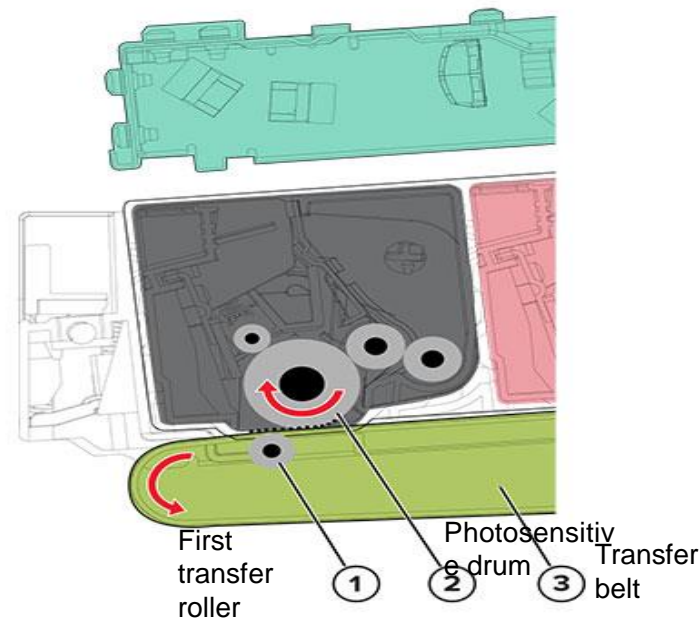

- ◆ Do not touch the surface of the transfer belt directly with your hands. The grease on the skin may cause a charge difference on the surface, which may prevent the toner from continuing to adhere correctly, and may cause periodic blank spots or light color printing on the page. Do not use solvents or other cleaning agents to clean the surface of the transfer belt. If surface scratches or charge differences are caused by solvents or other cleaning agents, blank spaces or light spots may appear on the printed page.

## 4.5 Imaging principle - Second transfer

On the transfer belt, the four color image will be transferred to the second transfer roller. When the image on the transfer belt reaches a predetermined point, the system will pick up the paper accordingly, so that the paper moves exactly between the transfer belt and the second transfer roller. HVPS transmits a voltage to the second transfer roller to generate a positive charge. When the image on the transfer belt reaches the second transfer roller, the negatively charged toner will stick to the paper, and then transfer the entire image from the transfer belt to the paper.

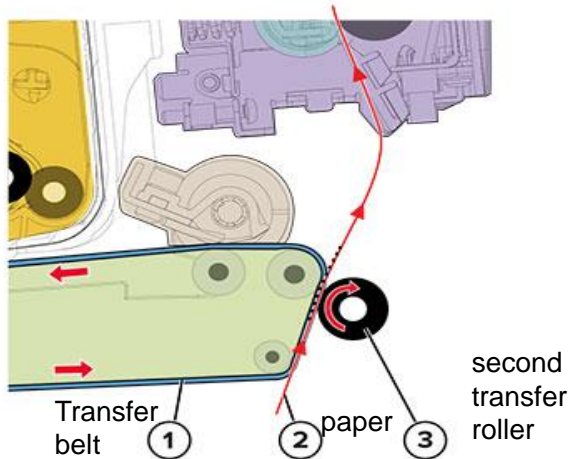

- ◆ If there are gaps, pits, or flat spots on the second transfer roller, its surface will not be able to contact the paper and transfer belt. The result may be blank or light dots (or periodic blank or light areas) on the page.

## 4.6 Imaging principle \_ fixing

With the help of the transfer roller, the paper with the image enters the fixing area. The fuser applies heat and pressure to the paper to melt the toner particles and permanently adhere them to the paper. The fuser moves the paper to the output roller, which then moves the paper to the paper slot.

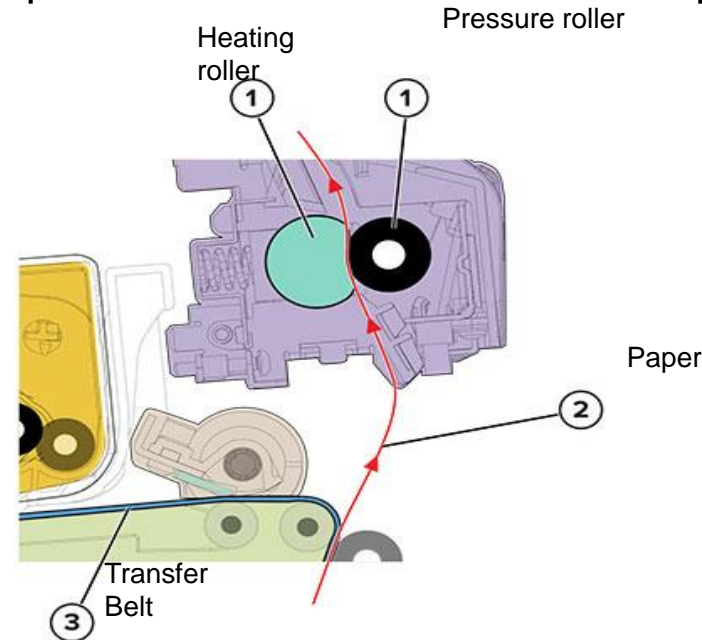

- ◆ The removal of toner from the paper indicates a faulty fuser or an incorrect paper type setting. Before replacing the fuser, please check the paper type settings. Common errors include printing on heavier media, such as card, while the paper type is set to general paper.

## 4.7 Imaging principle - Clean

There are two cleaning processes that the printer will perform during the image forming process, these two processes will remove residual toner from the related module.

Transfer belt clean

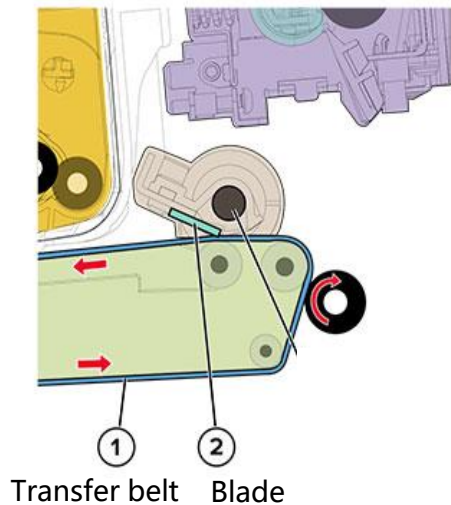

OPC clean

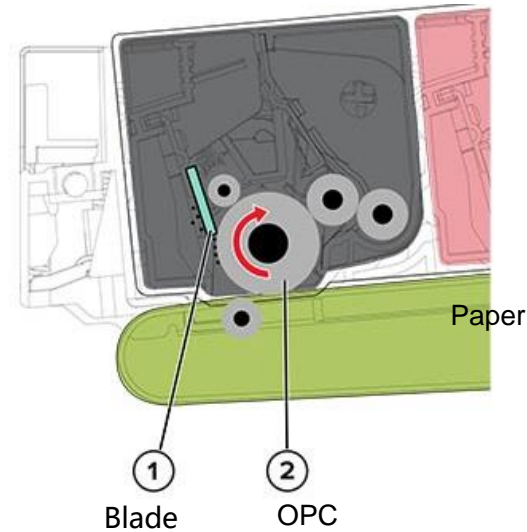

- ◆ The removal of toner from the paper indicates a faulty fuser or an incorrect paper type setting. Before replacing the fuser, please check the paper type settings. Common errors include printing on heavier media, such as card, while the paper type is set to general paper.

### Question and Answer:

Which of the following printing principles is different between color printer and monochrome printer?

1. Charge
2. Exposure
3. Developer
4. First transfer
5. **Second transfer**
6. Clean
7. Static Removal
8. Fixing





# SECTION 03

## Machine Component Structure

## Explosion Map

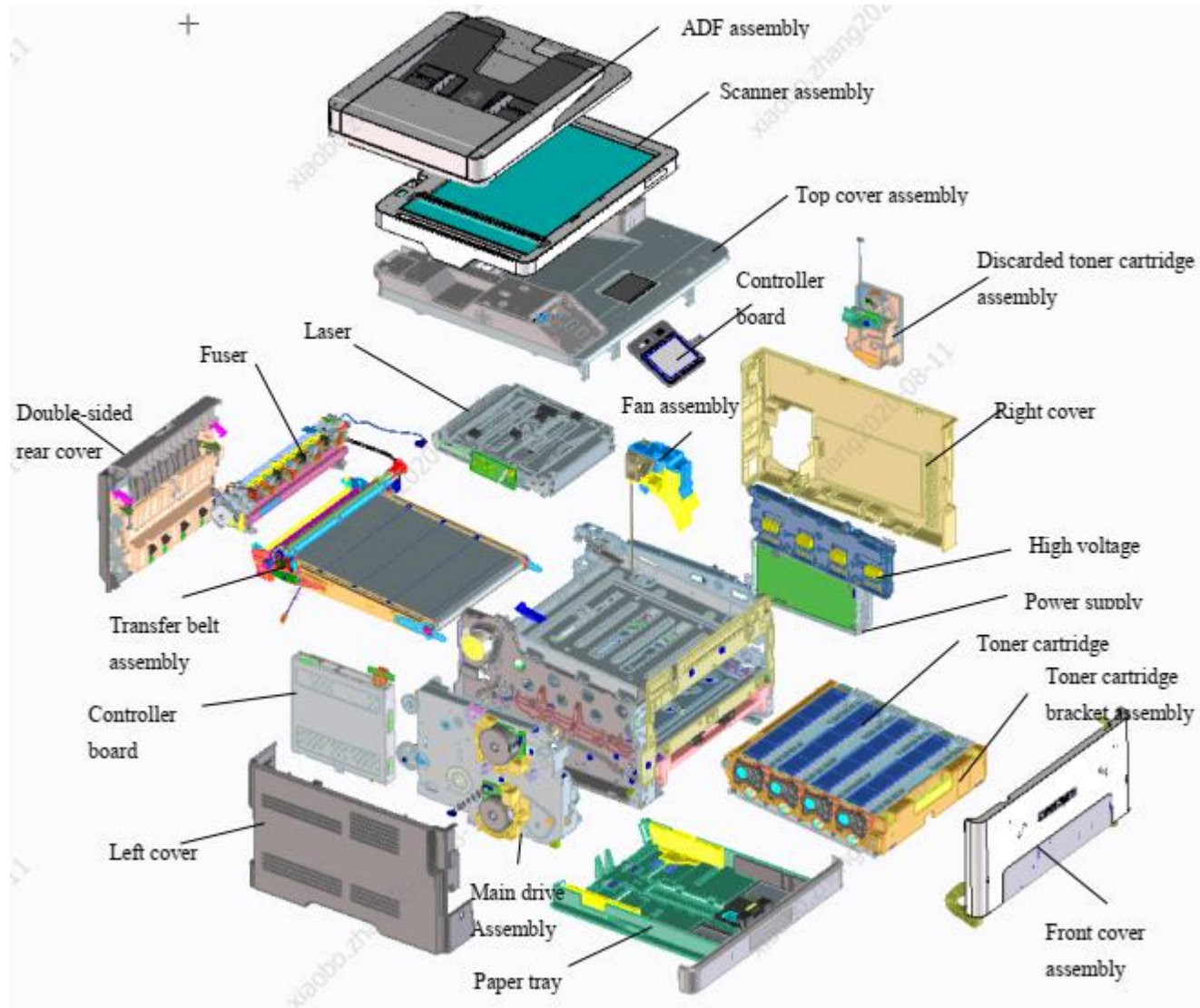

## Printer Paper Path

ADF Paper Path Picture

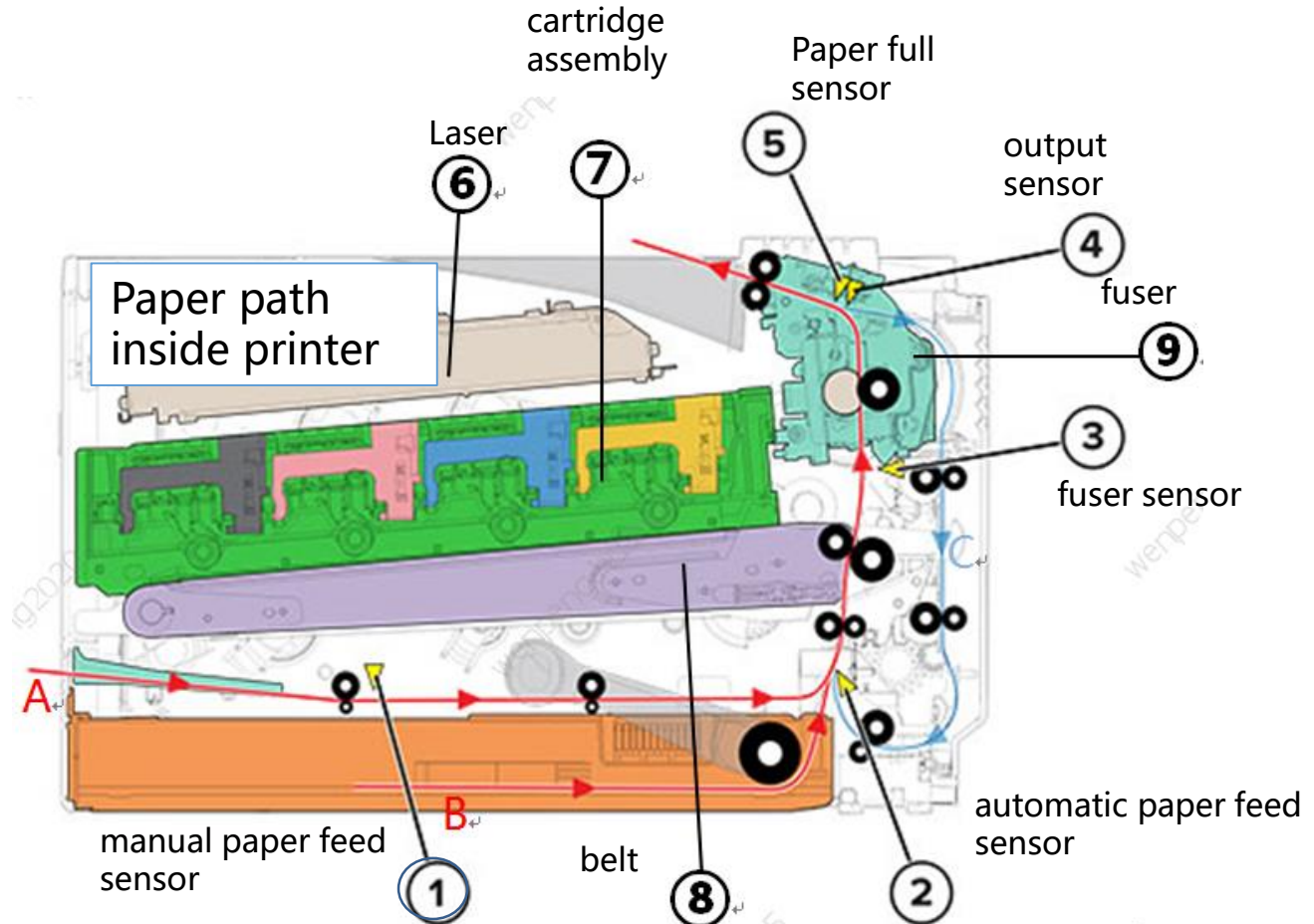
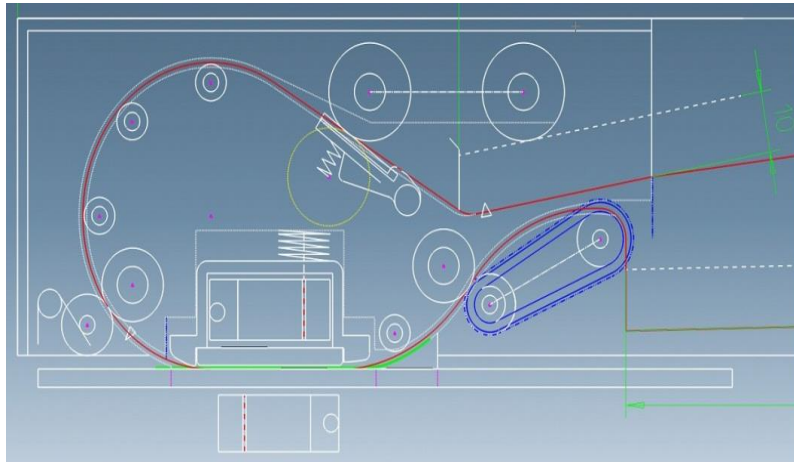

Component Name	Main Function
ADF paper presence sensor	Check whether there is paper on the paper feed tray.
ADF front sensor	Check whether the top of paper was out of shaped or whether there is paper jam issue exists.

Component Name	Main Function	Component Name	Main Function
manual paper feed sensor	Check whether there is paper on the paper feed tray.	fuser sensor	the switch of rear
automatic paper feed sensor	Check whether the top of paper was out of shaped	Paper output /Paper full sensor	Detect the paper output of fuser and whether the paper are full

## Roller Graphic

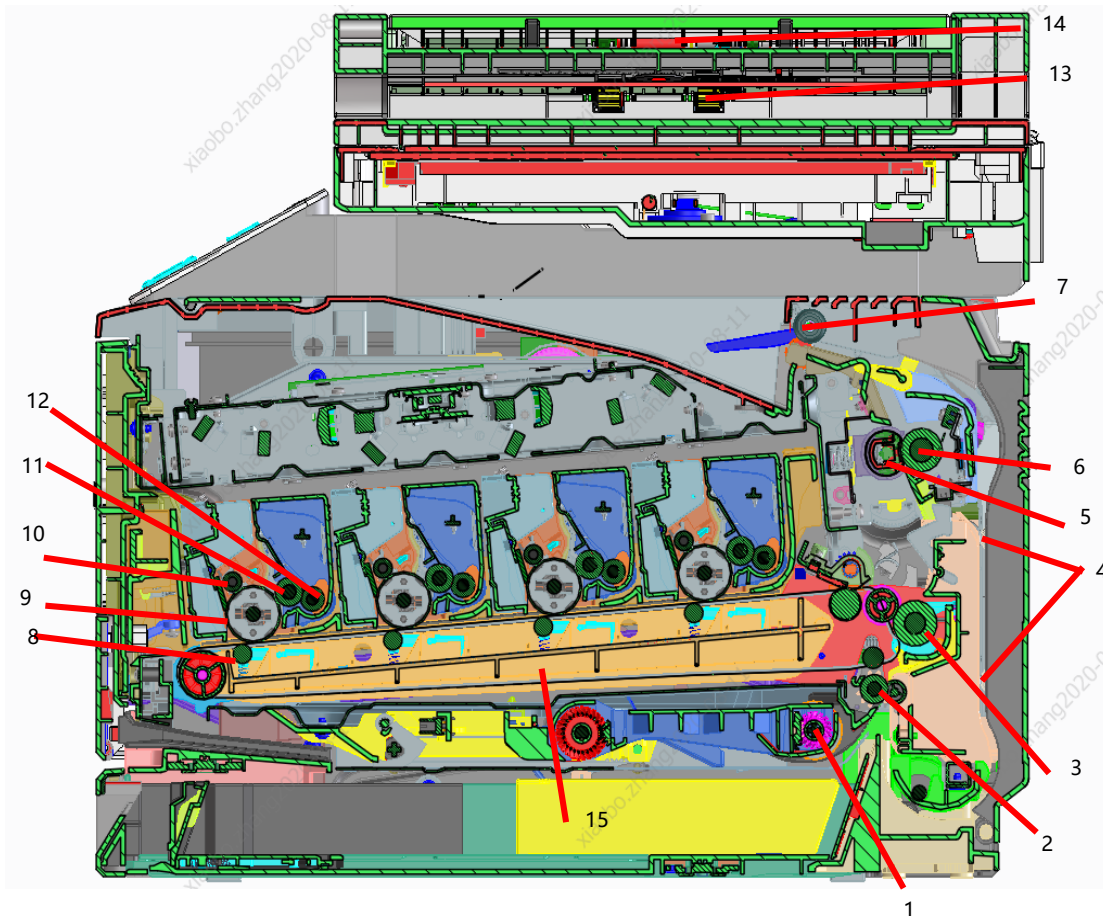

No	Name	Picture period mm
1	Paper pick-up roller	-
2	Tip correction roller	-
3	Second transfer roller	59.7
4	Double-sided printing correction roller	-
5	Fusing heating roller	57.5
6	Fusing pressure roller	57.3
7	Paper output roller	-
8	First transfer roller	25.1
9	Photosensitive drum	75.4
10	Charging roller	25.7
11	Developing roller	26.6
12	Toner feeding roller	-
13	ADF paper output guide wheel	-
14	ADF paper feed roller	-
15	Transfer Belt	655

## ADF、 Scanning unit

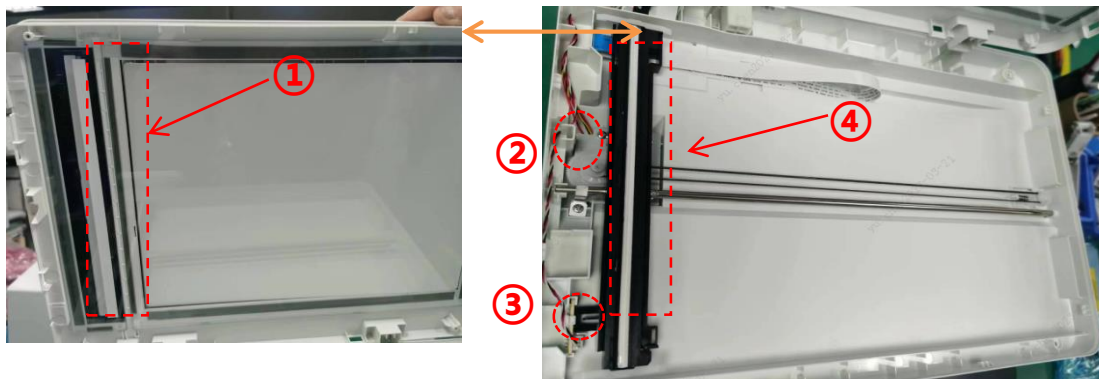
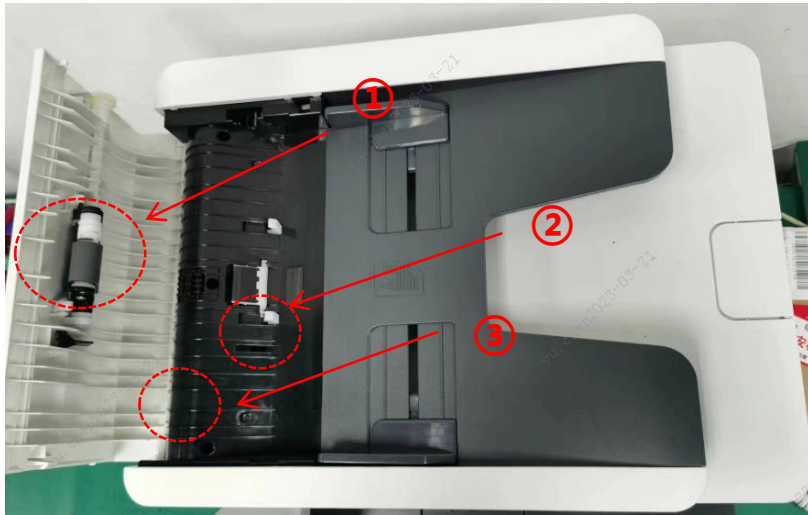

### ◆ ADF Components: automatic document feeder

- ① ADF Pick up Roller: pick up paper into path roller.
- ② Automatic document feeder: Check whether there are original paper inside the paper tray.
- ③ Front Sensor: Check the front part of paper or whether there is paper jam issue exists.

### Scanning Platen:

Scan the original file through the Scanning Platen:

- ① White bars and black marks: for scanning positioning
- ② Scan motor : scan driver
- ③ Positioning sensor : CIS original location positioning
- ④ CIS: Scanning head converts optical signals into electrical signals

## Control Panel Module

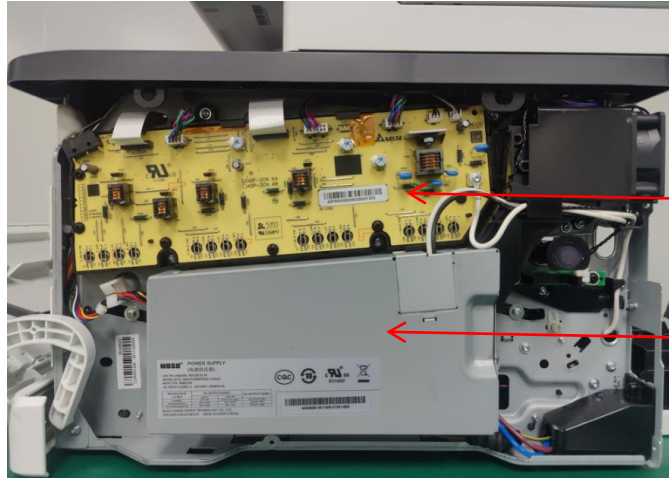

③

②

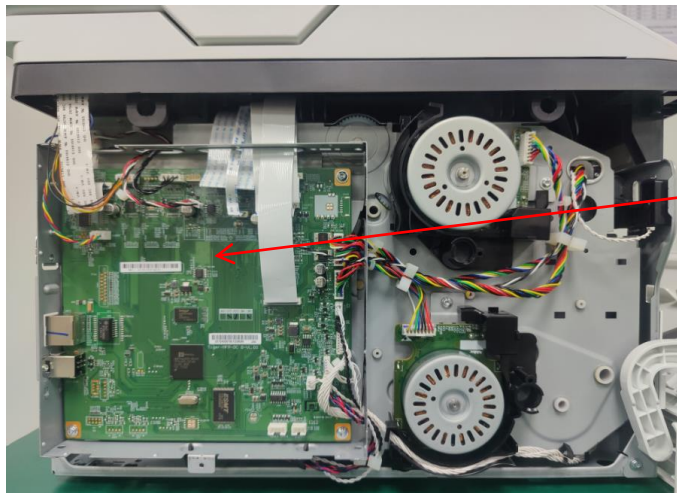

①

◆ **Base board:** main control + engine + low voltage + high voltage

① **Data board :** Main control

② **Power board:** low voltage

③ **Engine board:** high voltage+engine

**Low voltage:** 220V power supply for fixing voltage and switching voltage to 24V, 5V ;

**High voltage:** for charging, developing, transfer high voltage;

**Main control :** image processing and data control;

**Engine:** various electrical components, such as motors, sensors.

## Imaging Module



Laser Unit



Cartridge assembly

**LSU:** laser print head, converts electrical signals into optical signals.

**Note:** The laser sends laser light from four windows (YMCK) to four photosensitive drums, which will form an electrostatic latent image.

- ◆ **Cartridge component:** drum powder integrated  
The number of printed pages is based on ISO standard portraits, standard environments, and standard paper. Therefore, the actual number of pages may not necessarily match the number of specified pages.  
**Note: Please do not change the color position of cartridges during installation**

## Imaging Module

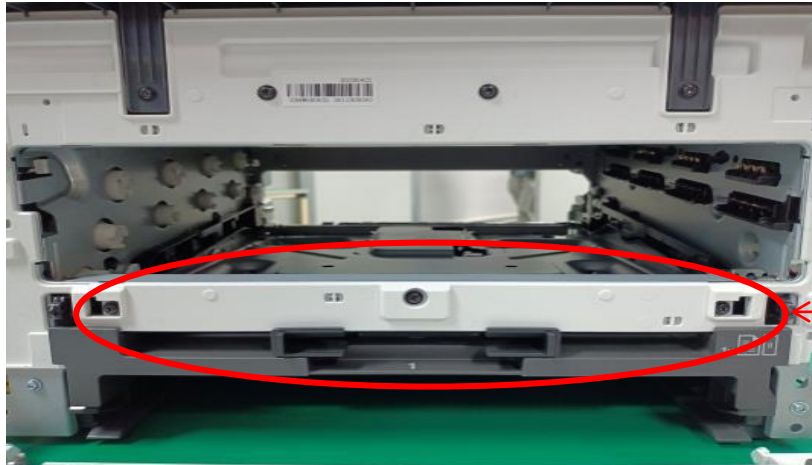

Toner spot sensor



Fuser

- ◆ **Toner spot sensor (IDC):** Toner density, color, and color calibration on the transfer belt.
- ◆ The printer automatically creates a fixed image on the transfer belt and calibrates the machine through the detection of this sensor.

### Fuser Unit: Press and Heat the paper with Ceramic

- ◆ **heating roller :** Transfer the heat of the ceramic to the belt to heat the paper
- ◆ **Pressure roller :** press with soft roll
- ◆ **Ceramic :** heating components
- ◆ **Temperature control switch:** when printer reach a certain temperature, it will disconnect the fuser power supply to prevent the fuser from heating up and protect the printer
- ◆ **Separating clutch:** separate paper

## Paper Feed Module

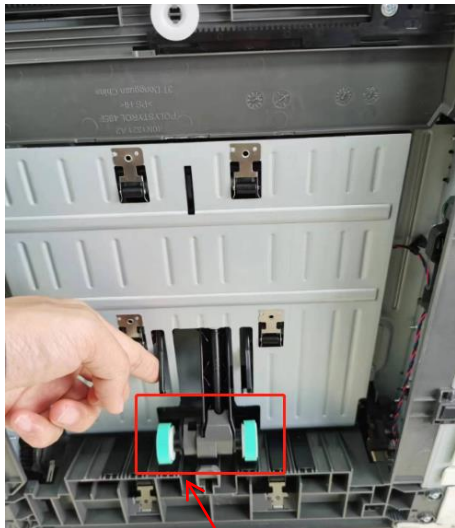

Pick up wheel

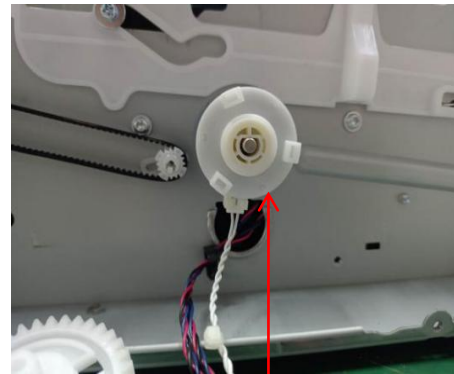

Paper feed clutch

### Paper Feed Module:

**pick up paper from the tray and form image**

**Paper feed clutch:** controls the rotation of the paper take-up wheel (paper pick-up timing)

**Paper pick-up wheel:** to take the paper into the machine

Note: this printer could not detect whether there are paper inside the tray, when there is no paper, a paper feeding failure error will be reported because of the excessively long paper feeding time sequence.



# SECTION 04

## Common Troubleshooting Method

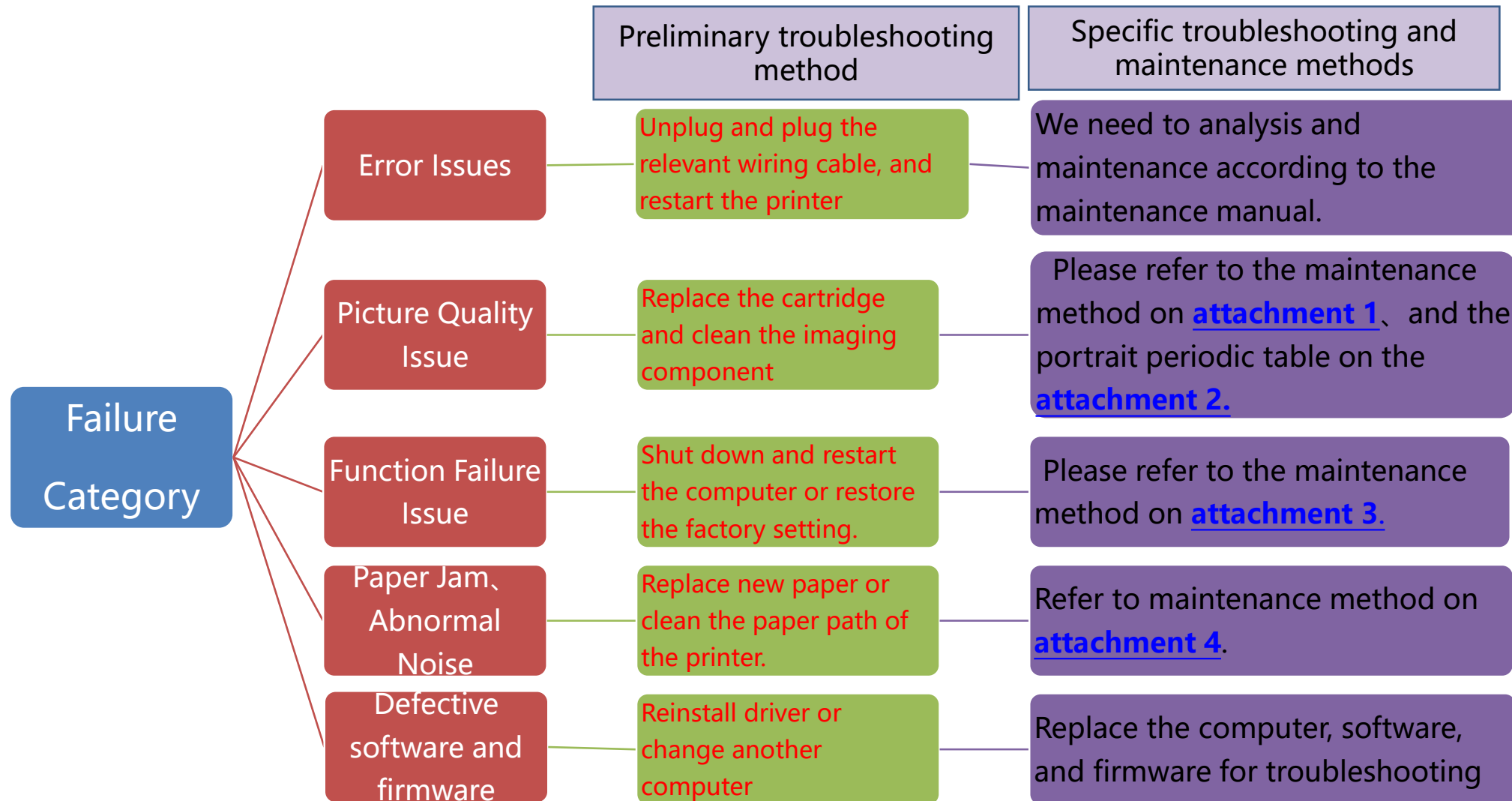

## 1. Image calibration method

When there are ghosting or significant color differences in the image, and major parts of the machine (such as LSUs, data substrates, etc.) are replaced, manual color calibration is required. The method is as follows:

### LED model:

Print driver procedure(computer) → "Printer properties" → "Printer settings" → "More settings" → "Printer system settings" → "Color calibration"

**LCD model:** Press the "Menu" key to enter the "Menu Settings" interface → "Print Settings" → "Color Calibration";

**Touch screen model:** Click the "Settings" button on the control panel → "Menu Settings" → "Print Settings" → "Color Calibration";

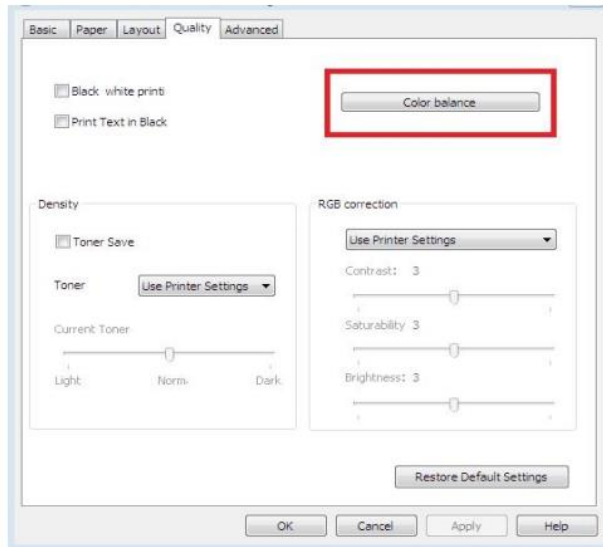

## 2.Repairment and replacement of data board/laser/IDC spare parts

When the printer leaves the factory, it is necessary to calibrate the laser and IDC components to ensure the quality of the image. The calibration data is stored on the data board. When the following situations occur, the calibration data is reloaded into the printer:

- 1.**After replacing the data board:** The laser and IDC calibration data on the original printer will be lost, and it is necessary to reload the laser and IDC calibration data from the original printer into the new printer.
2. **After replacing a laser or IDC:** it is necessary to replace the calibration data of this component of the old printer with the calibration data of the new spare part.

The data and loading tools in this section can be downloaded from the after-sales service system. For specific methods, please refer to the maintenance manual.

## 2.Repairment and replacement of data board/laser/IDC spare parts

Step 1 : Open the "1820 Calibration Data Upload Tool", use the tool to send the calibration file to the printer, and use "Run as Administrator".

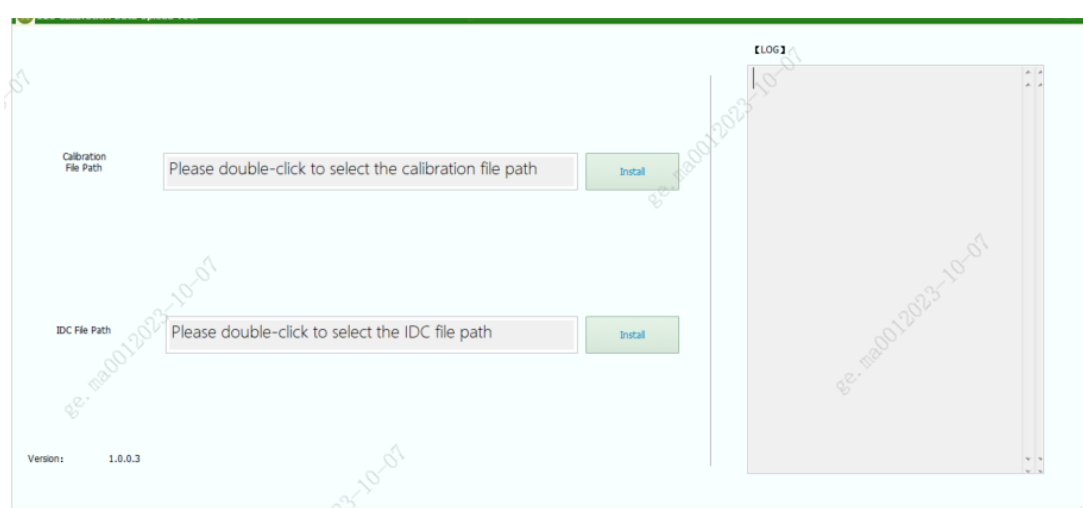
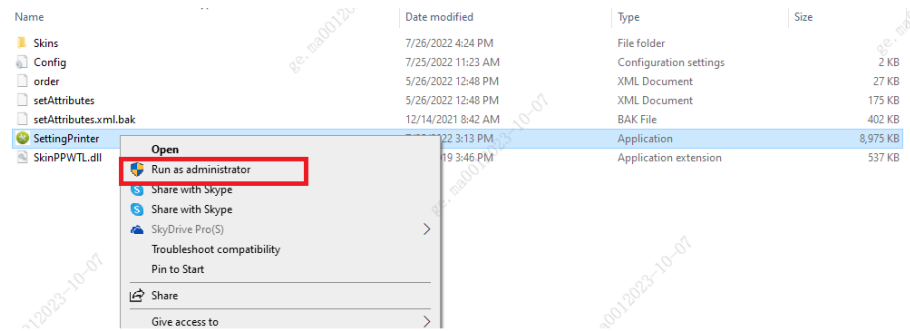

## 2.Repairment and replacement of data board/laser/IDC spare parts

Step 2 : Double-click to select the downloaded calibration file, click "One-click Settings", the file will start to be automatically uploaded to the printer, and the printer will be ready after automatic calibration is completed.

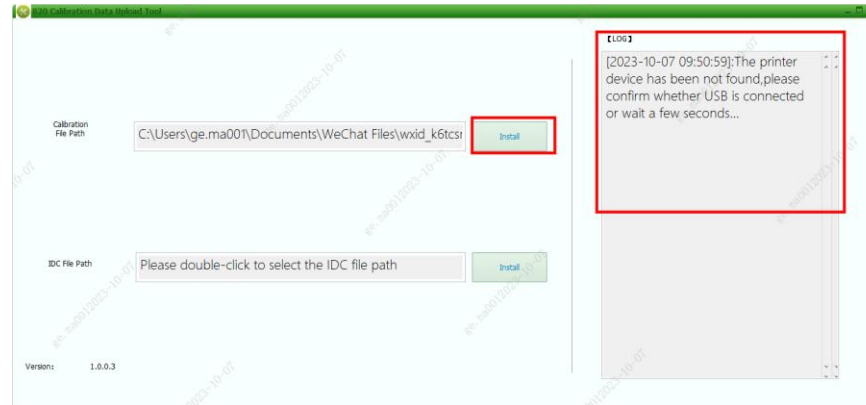

Step 3 : Double-click to select the downloaded IDC file, click "One-click settings", and the file will start to be automatically uploaded to the printer. The printer will be ready after the upload is completed.

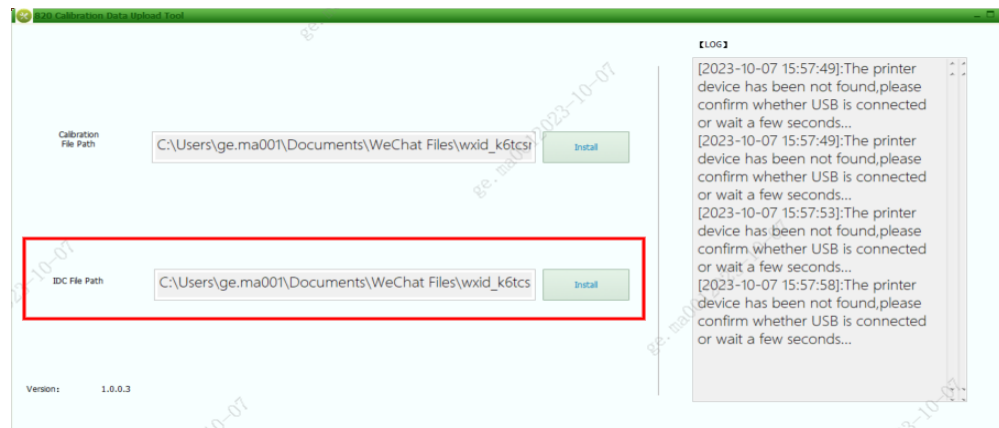

## 3. "01.001" Troubleshooting Methods

### Problem Description:

When the printer is turned on to print the first page , the panel reports "Printer Internal Error - 01.001"

### Reason analysis:

1. The working temperature of the printer is 0~5 degrees lower.
2. The printer input voltage is unstable.
3. Defective power board&data board.

### Corresponding method:

1. Place the printer in a suitable temperature environment. (10~35 degrees)
2. Place the printer on a stable power supply environment.
3. Replace power board&data board.



## 4. processing method for the error "Printing vertical black/colored lines"

### Problem description:

When the printer is printing, black or colored vertical lines appear on the image.

### Reason analysis:

- ✓ 1. There are gaps or foreign matters in the cleaning scraper.
- ✓ 2. Foreign matter or toner adhered to the charging roller.
- ✓ 3. Defective transfer belt.

### Corresponding method:

- ✓ 1. Replace the cartridge assembly.
- ✓ 2. Clean or replace the transfer belt.

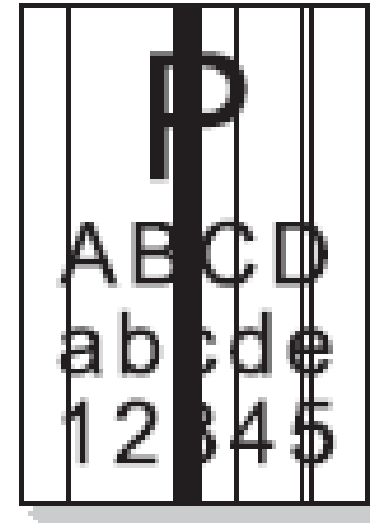



# SECTION 05

## Introduction of the Maintenance Manual

## Table of Contents

1. Before Using the Printer.....	1
1.1. Product series introduction .....	1
1.2. Supplied Accessories .....	2
1.3. Product View.....	3
1.4. Laser Toner Cartridge.....	6
1.5. Control Panel.....	7
1.5.1. Overview of control panel .....	7
1.5.2. Indicator function of control panel.....	8
2. Paper and Print Media .....	10
2.1. Paper Specification .....	10
2.2. Special Paper .....	11
2.3. Loading Paper .....	12
2.3.1. Install the multipurpose feed tray.....	12
2.3.2. Installing automatic tray.....	13
2.3.3. Installing optional tray.....	16
2.4. Non-printable Area.....	18
2.5. Paper application rules .....	18
3. Driver installation and uninstallation .....	19
3.1. Driver Setup.....	19
3.1.1. One-click Installation(For Windows and macOS).....	19
3.1.2. More setup methods.....	33
3.2. Uninstall Driver .....	46
3.2.1. Method to uninstall driver under Windows.....	46
3.2.2. Method to uninstall driver under macOS .....	46
4. Wired network setup (applicable to wired network models).....	47
4.1. Set IP Address.....	47
4.1.1. Automatic Setting .....	47
4.1.2. Manual Setting.....	47
5. Wireless network setup (applicable to Wi-Fi models).....	48
5.1. Basic structure mode .....	48
5.1.1. Wireless network setup tools.....	48
5.1.2. Wi-Fi Protected Setup (WPS) setup .....	52
5.1.3. How to disable the Wi-Fi network connected .....	53
5.2. Wi-Fi Direct mode .....	53
5.2.1. Preliminary preparations.....	53
5.2.2. Wi-Fi Direct connection .....	53
5.2.3. How to disable the Wi-Fi Direct .....	53

◆ Attached: 1820 Maintenance Manual



Pantum CM1100  
ies Service Mani

## Introduction of Our Aftersales system.

<https://csspi.pantum.com/admin/common/main.jhtml>

The screenshot displays the Pantum Service Team Knowledge Base interface. The page header includes the Pantum logo, 'Pantum Service Team', and 'Overseas site: 中国'. The navigation sidebar on the left contains 'Basic information', 'My information', 'Spare parts information', 'Series number', 'Knowledge base', and 'Business process'. The main content area is titled 'Knowledge base' and features a search bar with 'Key words' and 'Category' dropdowns. A table lists various knowledge base entries with columns for Title, Category, Create Time, Attached file, and Proceed. A dropdown menu is open over the 'Category' column, showing options like 'Spare Part Information', 'Spare Part BOM List', 'FAQ', 'Training Video', 'Disassemble Video', 'Operation Video', 'Operation guide', 'Technical Service Bulletin', and 'Service Manual'. The table entries include titles such as 'How to scan to network folder on CM2200 via wifi connection', 'How to scan to SMB on BM5100 series printer', 'How to open the scan application software with wired network connection', and various service manuals for different printer models. The bottom of the page shows a pagination bar with '1' selected, '共 106 条', and '50 条/页'.

Title	Category	Create Time	Attached file	Proceed
How to scan to network folder on CM2200 via wifi connection	Operation Video	2023-06-25	Download	View
How to scan to SMB on BM5100 series printer	Operation Video	2023-06-09	Download	View
How to open the scan application software with wired network connection	FAQ	2023-05-31	Download	View
Pantum BM270, BM330, BM420 Series Service Manual	Service Manual	2023-05-23	Download	View
Pantum CM270, CM330, CM420 Series Service Manual	Service Manual	2023-05-23	Download	View
Pantum CM9700, CM9100, M9700, M9100 Series Service Manual	Service Manual	2023-05-19	Download	View
Pantum P3300 disassembly video - How to replace powerboard	Disassemble Video	2023-05-15	Download	View
Pantum P3300 disassembly video - How to replace databoard	Disassemble Video	2023-05-10	Download	View
Principle of Color Laser Printer	Training Video	2023-05-08	Download	View
How to complete work order entry on Pantum CRM	Training Video	2023-05-08	Download	View
Pantum CP2100 Series Service Manual	Service Manual	2023-05-08	Download	View
Pantum M6550 Disassemble Video	Disassemble Video	2023-05-08	Download	View
2013MFP (M6550) Pantum technical training	Training Video	2023-05-08	Download	View
*** [2013 Series Explosion Map] ***	Spare Part Information	2022-12-27	Download	View
Pantum PT-D160 Series Service Manual	Service Manual	2022-09-23	Download	View



# SECTION 06

## Printer Disassembly

## 6、 Printer Disassembly



- ◆ Carry out disassembly and assembly practice on the printer according to the maintenance manual .

Please scan the QR code to tell us your opinion, thanks.



PANTUM



AFTER-SALES  
SERVICE

# Thanks

Customer Service

[WWW.PANTUM.COM](http://WWW.PANTUM.COM)

